

# ANELLO ROTANTE ROTARY INDEX TABLE

## AR800 / 801E

PESO / Weight Kg.500

**AR800**

DISPONIBILE SU DISCO CAD  
Available on CAD disc

FILE  
W41950

**AR801E**

DISPONIBILE SU DISCO CAD  
Available on CAD disc

FILE  
W42019

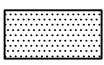

**ROTANTE  
ROTATING**

N°8 FORI Ø12.5 PASSANTI  
N°8 through holes i.d.12.5

N°2 FORI Ø12H7 PASSANTI  
N°2 through holes i.d.12H7

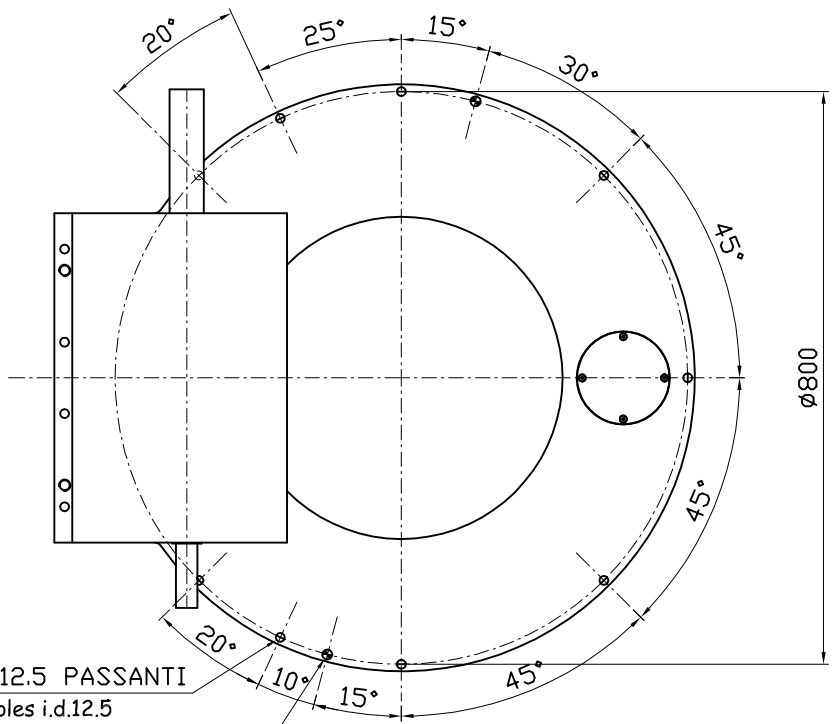

	A
AR800	61
AR801E	70.5

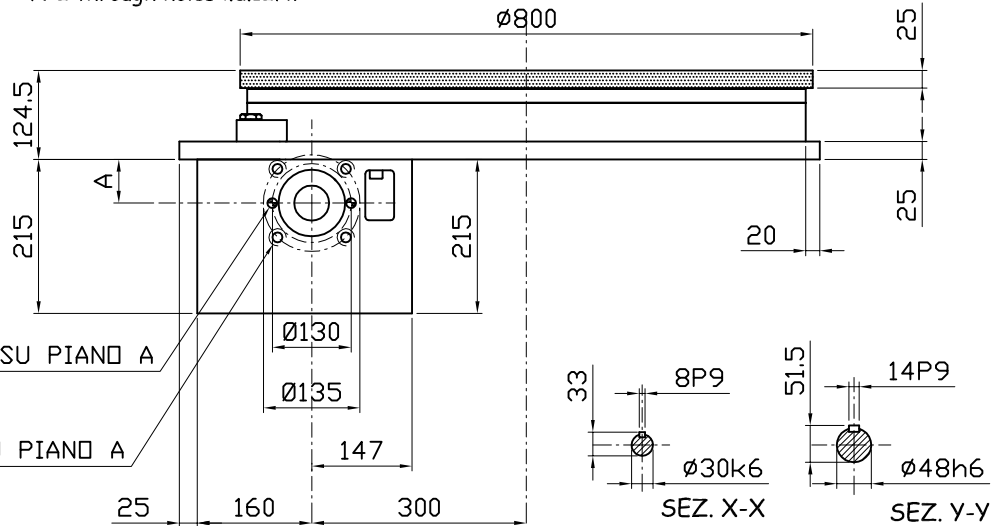

N°2 FORI Ø10H7 PROF.=25 ANCHE SU PIANO A  
N°2 holes i.d.10H7 depth=25 on plane A too

N°4 FORI M12 PROF.=25 ANCHE SU PIANO A  
N°4 M12 holes depth=25 on plane A too

PIANO A  
Plane A

